

## Stainless Steel ASTM A182, ASME B16.5 150lb Welding Neck Flanges

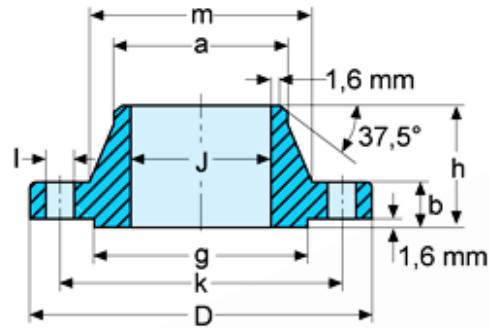

Pipe	Flange				Hub	Raised face	Drilling template		Weight			
Nom.size	O.D.	D	J	b	h	a	m	g	l	k	No. of holes	kg/pce
in.	mm	mm	mm	mm	mm	mm	mm	mm	mm	mm		
<b>0.5</b>	21.3	88.9	15.7	11.2	47.8	21.3	30.2	35.1	15.7	60.5	4	0.48
<b>0.75</b>	26.7	98.6	20.8	12.7	52.3	26.7	38.1	42.9	15.7	69.9	4	0.71
<b>1</b>	33.4	108	26.7	14.2	55.6	33.5	49.3	50.8	15.7	79.2	4	1.01
<b>1.25</b>	42.2	117.3	35.1	15.7	57.2	42.2	58.7	63.5	15.7	88.9	4	1.33
<b>1.5</b>	48.3	127	40.9	17.5	62	48.3	65	73.2	15.7	98.6	4	1.72
<b>2</b>	60.3	152.4	52.6	19.1	63.5	60.5	77.7	91.9	19.1	120.7	4	2.58
<b>2.5</b>	73	177.8	62.7	22.4	69.9	73.2	90.4	104.6	19.1	139.7	4	4.11
<b>3</b>	88.9	190.5	78	23.9	69.9	88.9	108	127	19.1	152.4	4	4.92
<b>4</b>	114.3	228.6	102.4	23.9	76.2	114.3	134.9	157.2	19.1	190.5	8	6.84
<b>5</b>	141.3	254	128.3	23.9	88.9	141.2	163.5	185.7	22.4	215.9	8	9.2
<b>6</b>	168.3	279.4	154.2	25.4	88.9	168.4	192	215.9	22.4	241.3	8	10.6
<b>8</b>	219.1	342.9	202.7	28.4	101.6	219.2	246.1	269.7	22.4	298.5	8	17.6
<b>10</b>	273	406.4	254.5	30.2	101.6	273.1	304.8	323.9	25.4	362	12	24
<b>12</b>	323.8	482.6	304.8	31.8	114.3	323.9	365.3	381	25.4	431.8	12	36.5
<b>14</b>	355.6	533.4	336.5	34.9	127	355.6	400	412.7	28.6	476.2	12	51
<b>16</b>	406.4	596.9	387.3	36.5	127	406.4	457.2	469.9	28.6	539.7	16	60
<b>18</b>	457.2 508.0	635.0 698.5	438.1 488.9	39.6	139.7 144.5	457.2 508.0	505.0 558.8	533.4	31.8	577.9 635.0	16	68.300 84.500 115.000
<b>20</b>	609.6	812.8	590.5	42.9	152.4	609.6	663.4	584.2	31.8	749.3	20	
<b>24</b>				47.8				692.2	35.1		20	